

38TYD-250-1 直流减速电机 DC GEAR MOTOR Series **SGMADA**®



电压/Main voltage: 3VDC、5VDC、6VDC、9VDC、12VDC、24VDC

用途/Typical applications: 孵蛋器专用电机也适用于其它自动化设备等
Special motor for eggincubator and other automatic equipment

重量/Weight: 40~45g/pcs(approx)

包装外形尺寸/Packing details: CTN size: 33.5X33.5XH29cm 100pcs/CTN G.W.11.3kgs

外形尺寸 APPEARANCE SIZE

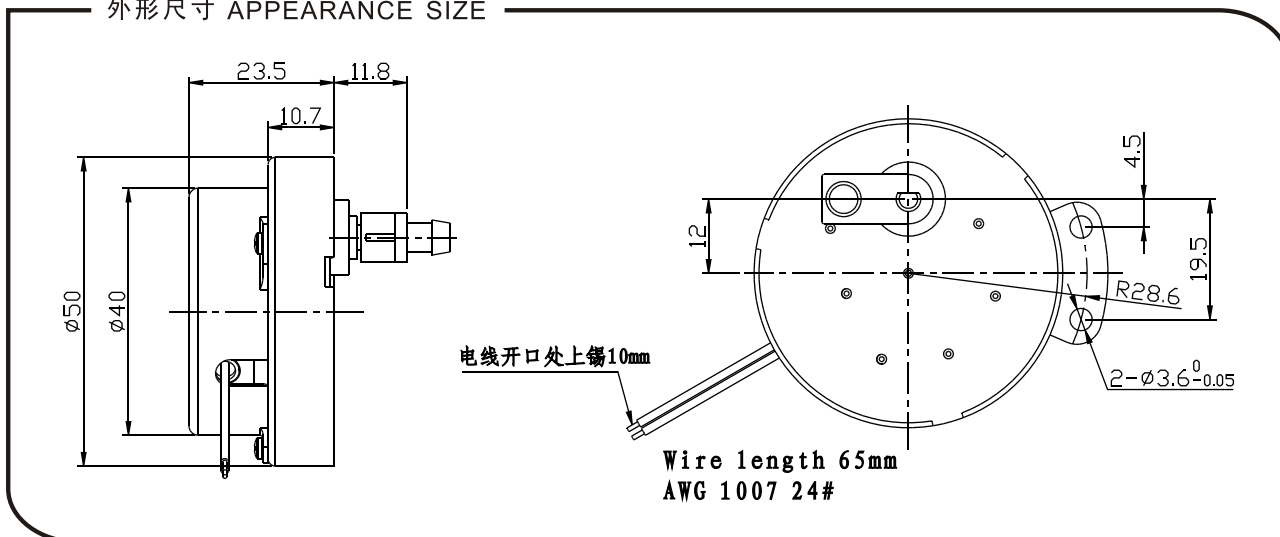

齿轮箱数据 Gearbox data

减速箱级数 Number of stages	4 减速比 Stages reduction
减速比 Reduction ratio	72000
最大运转力矩 Max. Running torque	5kgf.cm
最大破坏力矩 Max. Gear breking torque	15kgf.cm
最高齿轮效率 Max. Gearing efficiency	20%
其它减速比请致电或邮件给我司技术部 Other reduction ratio please telephone or e-mail to our engineering department.	

技术参数 MOTOR SPECIFICATIONS

电机型号 MOTOR MODEL	尺寸 Size (A) mm	额定电压 Rated Volt. V	最大效率点 At maximum efficiency				
			频率 Freq.	电 流 Current	转 速 Speed	扭 矩 Torque	输入功率 Input
			Hz	mA	r/min	g. cm	Power(W)
38TYD	16.5	220 240	50	0.25	2450	140	26
38TYD	16.5	100 120	60	0.28	2600	140	27